

STATIONERY DESIGN OF AGING SOCIETY — WITH STAPLER AS A CASE STUDY

* Chun-Hsien Chiang¹, Chang-Franw Lee², Yu-Cheng Chen¹, Huan-Chung Chiu¹

¹Department of Product Design, Transworld Institute of Technology, Taiwan

²Graduate School of Industrial Design, National Yunlin University of Science and Technology, Taiwan

ABSTRACT: This paper aims at exploring the using status and improvement of stapler for the elderly. This study integrates the labor-saving structure into the design of three new staplers, based on the best grip proposed by relevant literature, whose operational heights are 42.8mm, 50mm and 55mm respectively. After conducting binding test onto 15 youngsters and 15 elderly, results obtaining through this study are as follows: 1) For labor saving and force application, the stapler with 42.8mm operational height is the most efficient one, whose binding force is 5.98kg. 2) For the three staplers designed for the elderly group in this study, labor-saving structural design can increase the operability for the elderly. The stapler with the best efficacy is in an operational height of 55mm, followed by 50mm and then 42.8mm. Besides considering the labor-saving structure, the design of stapler also takes simplified operation into consideration. The experimental results in this study reveal that it can effectively increase the whole efficiency for the elderly through taking 50mm as the operational height as it can reduce the operational strength and shorten the action distance.

KEYWORDS: Stationery Products, Elderly, Stapler

1. INTRODUCTION

With the development of medical science, people's average life expectancy is being expanded. In developed countries, the population of the elderly increases faster than that of the youngsters. That is the case of the life expectancy in U.S. and other countries. Rowe and Kahn (1998) pointed out that the life of people is naturally increasing. They estimated that the average life expectancy of all human beings is about 65 years or even longer (Arthur D. Fisk and Wendy A. Rogers, 2002).

Especially after the urbanization, the life environments for most modern people have been in urban areas by replacing countryside. So the family model is transformed from the huge into the small type, which is mainly composed of wife and husband.

Moreover, for family income source issues, under the increasing price mentioned above, the old family model, "Men be responsible for livelihood while

women for housework", cannot cope with the large amount of family expenditure any more. Thus, double-income family comes into being and becomes prevalent.

Influenced by aging society and lower birth rate, the elderly living alone and the expenditure of social welfare may increase, which will be a large burden of the social welfare. For this reason, retirement age might be raised so as to relieve this huge financial burden of future social welfare.

This study will start from the perspective of raising the retirement age to explore how industrial design can provide some assistance for the elderly in their working market.

1.1 Study Motivation

Based on the estimation by the Council for Economic Planning and Development, Executive Yuan, the elderly aged 65 or above will reach 10% of the total population in 2012, and 20% in 2022.

The aging speed is apparently faster than that in western countries. In industrialized society, people still expect to get guarantee from their work and rely on non-family income to support their old age life (Zhan Huo Sheng, Wang Yi Ren, Xiao Hui Ru, June 7, 2002). The more independence the elderly can maintain in their life, the lower the burden their children shoulder will be (Lian Jun Ming, 2004). Under this circumstance, a major change may be made in future retirement pattern. The application of the elderly resources will be the thinking direction of governmental agencies and professional scholars. The future working environment will be such an environment with coexistence of both the elderly and the middle-aged persons. Stationery is the most commonly-used product in offices. However, does the stationery in office has any problems in usage by the elderly whose physiological functions are deteriorated each year? In addition, stationery product is cheap. How can the elderly benefit from the convenience of the product as well as meet their special demands brought by physiological function deterioration. This is the motivation of this study.

1.2 Study Purpose

Future working environment will be under coexistence of both the elderly and the middle-aged persons. Stationery is the most commonly-used product in offices. However, does the stationery in office have any problems in usage by the elderly whose physiological functions are deteriorated each year? Based on this motivation, the following study purposes are extended:

1. Learn the usage situation of stationery product of binding type in terms of the elderly.
2. Discuss the best size and force application of stapler.

2. LITERATURE REVIEW

2.1 Occupational Hand Injuries

In an empirical study onto occupational disease

monitor—upper limb injuries conducted by Institute of Occupational Safety and Health, Council of Labor Affairs in 1996, the results of questionnaire filled by labors in each class reveal that repeated operations may cause discomfort in shoulders, elbows, wrists or hands, among which the wrist and fingers are most probably to represent such symptom.

Hand injuries can be divided into two types. One is the trauma caused by accidental events, such as smashing the finger and wounding the palm; the other is pathological changes caused by cumulative effect, such as carpal tunnel syndrome, tenosynovitis, trigger finger and ischemic, which are rarely be written in accidental injury report. However, they may cause reduction of output, lower working quality, increasing absence days, even accidents, which may finally result in the trauma. Various inappropriate hand tool designs or working design may easily bring pains or injuries to the upper limb. The reason why hand tools cause injuries to upper limb can be divided into four aspects.

Table 1 Reasons for occupational hand injuries

Type	Description
Strength	The strength applied to the tools is significantly related to the pains or injuries to the upper limb, such as pliers, alice's stick and hexagonal wrench. They need a certain amount of strength from the elbow, wrist and hands. Therefore, these tools have apparent connection with the injuries to the mentioned parts.
Gesture	Abnormal gestures in certain kind of work are caused by inadequate design of working site or hand tools. They require the working staff to operate tools in high-risky gestures. For example, pliers, diagonal cutting pliers, air shears, decomposition knives and plastic knives, all of which require the workers to operate with abnormal gestures due to the inadequate design. So it can easily cause improper gestures

	such as wrist ulnar deviation, radial deviation, buckling and stretch. Moreover, these kinds of hand tools are related to the pathological changes on the wrist.
Repeatability	Higher the repeated frequency is, more wear the work will cause to the organisms, such as tendons, ligaments and nerves. Also it needs much more time to recover from tiredness. These types of work don't need much strength. However, the high repeatability may easily cause accumulative injuries.
Shock	As some hand tools, especially some power-driven or pneumatic tools, do not equipped with efficient shock absorber, many workers have complaint about the too much shock, which may directly cause injuries to hand and require workers must use more strength to take these tools, which will cause the inaccurate assembling. Then the working efficiency is decreased.

To sum up, the upper limb is the part that workers use most during operation process. However, many hand tools can not provide safe and effective operation experience in spite of simple design. That's the fact especially in the case of repeated operations. Therefore, taking the elements of hand tools design into consideration will benefit more users.

In the past years, the main problem caused by Ergonomics is the overload of physical strength. While for now, it is lower-level and long-term exposure (e.g. office work). Figure 1 is the proportion of the reasons for occupational musculoskeletal injuries in offices. General office work accounts for 35%, computer-related work accounts for 33%, lifting and carrying work accounts for 32%.

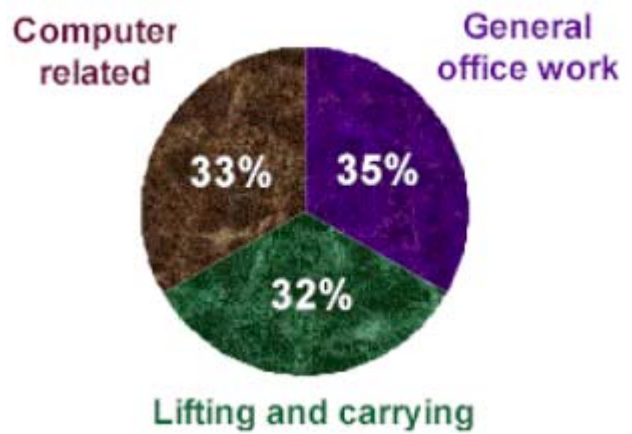

Fig. 1 Proportion of reasons for occupational musculoskeletal injuries in the office

For the musculoskeletal injuries caused by general office work, there are 6 items:

1. Inadequate tool configuration exceeds user's normal or maximum holding radius.
2. No appropriate back support.
3. Lack of appropriate hand (wrist and elbow) support .
4. Long-term abnormal sitting gesture.
5. Operation of vibration tools.
6. Using of stapler or similar tools

2.2 Optimal Hand Grip

Based on the proposed optimal grip (see Table 2), the range of the maximum is 50~60mm for male, while it is 38~60mm for female. This study takes this data as the reference for design of new stapler.

Table 2 Suggested optimal grip for male and female

Scholar	Male	Female	Remarks
Chaffin			Chaffin pointed out that the maximum grip strength can be applied when the grip is within 50mm-80mm. If considering the adventitious grip strength for over 95% of the female is under 90N \nwarrow span-style grip \nearrow , while the maximum grip strength of cylindrical-style grip can be applied when the grip is around 40mm.
Bechtol (1954)	51 mm	38 mm	
Herzberg (1955)	64 mm		
Petrofsky et.al. (1980)	63 mm		
Fransson	55-65	50-60	

&Winkle (1991)	mm	mm	
Lin Qing Quan & Xie Guang Jin (2000)	60 mm	50 mm	A grip of 40 mm is not convenient for the males to apply strength, while that of 70mm is not convenient for females in contrast.
Professor You Zhi Yun (1998)	A grip of 50mm is better for both male and female compared with 30mm and 70mm. So it is suggested that the grip to be set between 40mm—50mm.		

2.3 Physiological functions of the elderly

With the increasing age, the physiological functions, including cognitive function, strength, flexibility, operation ability, memory ability and learning ability, of the elderly will deteriorate (Fisk & Rogers, 1997). The change in visual function is the most obvious one. The vision of the elderly over 65 years old apparently decreases. They cannot clearly see things. The next is the adaptability to and sensibility of brightness as well as the reception of colors, all of these will influence the elderly's daily life (Zhan Huo Sheng, 2000).

Baltes and Baltes (1990) pointed out that normal deterioration is a deterioration with no physical or mental diseases. In case being influenced by diseases, the deterioration of functions will speed up dramatically. The factors affecting this include age, health, physical exercise, working and social activities. Moreover, the deterioration of visual and cognitive functions is the key factor influencing the elderly's operations (Guo Chen Jia, 2001). In addition, the deterioration of mental functions, such as memory, thinking and evaluation (Liu Chun Tang,

1998), will bring significant influence on individuals. With increased spare time, the elderly may have a larger gap towards the practical life culture and cognition if their opportunities of social connection and self-study reduced (Liu Chun Tang, 1998), which may more likely to accelerate the deterioration of their mental functions. However, the speed of deterioration is individualized.

Zhang Ci Ying (2005) proposed that the coming aging society will undoubtedly raise many social problems, but on the other hand, it may also give the society many opportunities. The analysis content is shown in Table 3.

Table 3 Crisis and opportunity of the aging society

Development of aging society	Crisis	Opportunity
Increasing population of elderly	Annuity volume increases, while individual capital decreases.	Demands of recreational products and service increase, and the demands of small-sized and more comfortable families increase as well.
Elderly of different generations	Low economic growth, higher dependency, difference between supply and demands	Creative and alternative products and service, the economic growth still has some room.
Much too arbitrary	The elderly form the dominant group to resist the discrimination against the aged. The conflicts between generations occur.	Demands of recreation and exercise, as well as training courses.
Expense is increased	Deeper generation	Expenditure increases,

	differences.	demands of comfort and life quality increases, and deposit has been transferred into investment. The last is economic growth.
Health improvement of the elderly	Demands of health care products change.	Lower the national health pressure. Demands of health care products increase.
Health deterioration	Increase the national health pressure. Demands of health care products change.	Demands of care products increase. Demands of care products change.
Physiological ability deterioration	Physical disability increases. The deteriorating parts in need of assistance and adaptation increase. The independency is lowered, while the support demands increase.	Demands of living aids increase, demands of barrier-free products and service increase, lay emphasis on comfortable and friendly purpose, demands of care and service increase
Technological development	Obstacle towards new things, technology is taken as the separation between rich people and others	New solutions to negative influence. Meet demands of new products and service
Other social development	Social exploitation, few volunteers, need more formal health	Demands of health care and service increase, demands of

care, no safe sense and satisfaction, more fluency, immigrants increase among the elderly	safety increase, demands of action-related products and service increase.
---	---

Application of new technology can help to work out new solutions to the problems in aging society. Observing the related demands of aging society we can find out that the demands of care products increases significantly in the aging society. Also the demands of recreational service and exercise increase. Moreover, the influence onto the economic scale shows an increase trend as well. As the age increases, the coordination and physiological functions of the elderly will decrease. Nervous system deterioration weakens their learning ability while the deteriorating musculoskeletal will weaken their strength and endurance. All of these situations are shown as below.

Table 4 Impacts from the elderly's physiological changes

Physiological structure changes	Impacts
<input type="checkbox"/> Central nervous system changes <input type="checkbox"/> Brain cells number reduces <input type="checkbox"/> Brain weight becomes lighter <input type="checkbox"/> Brain blood flow reduces <input type="checkbox"/> Autonomic nerve system deteriorates	<input type="checkbox"/> memory deterioration, easy to forget things <input type="checkbox"/> weaker learning ability <input type="checkbox"/> weakening logic thinking ability <input type="checkbox"/> slow in response <input type="checkbox"/> insensitivity
<input type="checkbox"/> musculoskeletal system changes <input type="checkbox"/> osteoporosis <input type="checkbox"/> spinal atrophy and rachiocamposis <input type="checkbox"/> articular and ligament sclerosis <input type="checkbox"/> articular cartilage wear <input type="checkbox"/> muscular area reduces	<input type="checkbox"/> osteoporosis, easy to cause fracture <input type="checkbox"/> bending body, the height is shorter <input type="checkbox"/> lower extremities functions, feel inflexible <input type="checkbox"/> arthritis <input type="checkbox"/> weakened muscular strength <input type="checkbox"/> lower agility <input type="checkbox"/> reduced endurance,

cannot last for a long time (Grip strength in 65 years old is 75% of that in younger periods.)

Quoted from Chen Jian Zhi, 2005, *Demands and Design of the Elderly's Living Aids*

The elderly over 65 years old may lose visual sensibility, with lower audio-cognitive abilities (Fisk et al., 2004). Although aging society brings some crisis, it gives us lots of opportunities as well (Zhang Ci Ying, 2005).

2.4 Definition of Stationery Products

Based on the stationery product category specified in this study, the table below shows the sorted special stationery recognized in related announcements.







Table 5 Special stationery (dangerous, chemical toxic or disposable) list announced by competent authorities

Category	Item
1. Chemical type of stationery	correction liquid, permanent marker, stamp pad
2. Adhesive type of stationery	instantaneous adhesive, super glue, resin, double-sided tape, paste
3. Metal type of stationery	pushpin, pin, pencil sharpener, art knife, scissor, blade, letter opener
4. Optical type of stationery	laser pointer
5. Recognized by competent authorities □ () represent s categories	Glue(2), watercolor pens (1), highlighter (1), roller ball pens (1), seal rainbow pens (1), stapler(3), UV money detector pens (4), lipstick glue(2), adhesive tape (2), Scotch invisible tape(2), brooch (3), compasses (3), spindle (3)

Based on application methods, stationery products can be mainly classified into the following six types: 1.Binding model, 2.Cutting model, 3.Preseving

model, 4.Writing model, 5.Correction model, 6.others. Therefore, this study displays the classifications and its description in table 6.

Table 6 Model analysis of stationery usage

Model	Description	Graphic example
Binding	Used to bind files, such as stapler, puncher	
Cutting	Used for cutting objects or files	
Preserving	Used to sort and store	
Writing	Used to write and draw	
Writing	Used for words or picture correction	
Others	Other purposes other than those listed above	

All styles and trademarks in the figures are owned by the manufacturers.

2.5 Structure and Design Standard of Stapler

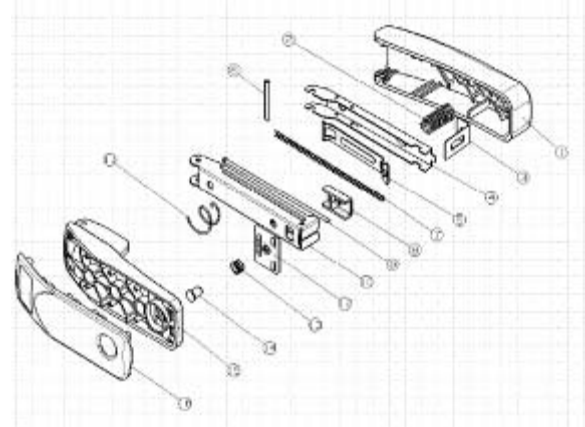

Figure 2 Explosive view of stapler components

The description of all components is shown as below

1. Cap: Help to press the drive cam.
2. Cap spring: control the movement of the drive cam.
3. Drive ram: a steel sheet to press the staples.

4. Case: hold drive ram and guide staples.
5. Pull plate: Open it and pull the follow back to put into the staple.
6. Hinge pin: assemble the cap, magazine and base.
7. Spring: pull and control the position of the follow block.
8. Follow block: pull the stapler pins to the edge of the stapler.
9. Bar: guide the spring of the follow back.
10. Magazine: put into staples.
11. Base spring: control the movement of the magazine.
12. Anvil: bend the staples pushed out by the drive ram.
13. Anvil spring: control and adjust the position of the anvil spring.
14. Anvil rivent: assemble the anvil, adjust knob, anvil spring and base.
15. Base: form the staples and help to apply strength during binding process.
16. Base slipper: stop slip of the stapler.

The design standard of stapler is shown in the table below.

Item	Specification	Standard
1	Staple size	NO.10
2	Maximum number of staples	50 or 100
3	Maximum number of binding paper (70gsm)	2-12 pieces
4	Freely drop onto the hard wooden panel from the height of 81cm(32")	Components can be taken apart, but they must can be reassembled with binding functions available.
5	Binding distance	Over 26mm
6	Maximum lifting angel of the cap component	Over 160°
7	Flexibility of the components	After binding, all function components can go back to their original positions smoothly.

8	After cap component presses, the drive ram shapes the size of the staples produced from the magazine	Over 0.2mm
9	The output quality	No two staples overlapped at one time or empty binding. Also, it can make use of all staples

3. EXPERIMENTAL DESIGN

3.1 Description of the Experiment



With the deterioration of physiological functions, the elderly's operational ability of daily necessities will apparently weaken. This study explores the best using method of staplers for the elderly and is proposed to design three types of samples with the same structure. Based on the optimal grip suggested by experts, 40mm~60mm, three sizes, namely, 42.8mm, 50mm, 55mm are selected in designing three staplers with different operational height. In this way, this study works out the most suitable stapler height for the elderly to operate.

3.2 Description of the Experiment Samples

This study only re-plans the size of the three staplers under design, while the shape is not concerned here. The specification and size are shown in the table below.

Table 8 Specification description of the three newly designed samples

Number	Sample 1
	H:42.8mm, L:109.1mm, W:28.6mm. Longer distance from the vacuum status to the binding position.
Specification and feature description	

Number	Sample 2
Specification and feature description	H:50mm, L:109.1mm, W:28.6mm. Moderate distance from the vacuum status to the binding position
	
Number	Sample 3
Specification and feature description	H:55mm, L: 109.1mm, W:28.6mm Shortest distance from the vacuum status to the binding position
	

Based on above design rules, this study develops the above three staplers in different heights. Resin material is taken as the plastic material for the samples by replacement of ABS material, therefore, the sample's physical characters do not match with that of mass produced material.

3.3 Experimental Design and Planning

The samples in this study are 5 types of staplers in different shapes, which may be put into operation and usability evaluation by both the elderly group aged 65 or above and the young group between 20-30 years old.

This experiment is composed of three stages, namely, fill in personal information and measure size values, conduct product operation test and interview of experimental results.

1. Personal information filling and size measure.

Fill in personal information and measure the grip value and hand size. The measurement of hand size mainly includes palm's length and width, and index finger's length. Measure the palm's size and the grip

value with slide caliper and grip meter.

2. Product operation test

Assign some binding tasks to all subjects (participants), and record the time they spending in accomplishing the task.

3. Interview of experimental results

Answer the questions raised by the interviewers based on personal feelings during the experiment. And write down the answers.

3.3.1 Experimental Subjects

The subjects in this study comprise of 15 members from the elderly and 15 from young people. The age of the elderly group ranges from 61 to 80, which are mainly from Erhlun Township, Yunlin County; while that of the young group, the members of which are mainly students, ranges from 22 to 27. The hand measure detail of the subjects and their basic information are shown in table below.

The average age of the elderly group is 70.9 while the average grip value is 27.3 Kg. In order to understand the difference obtaining from the stapler experiment between the elderly group and young group, this study conducts another test to the young group, whose average age is 24.7. The average grip value of the young group is 35.6 Kg, about 1.4 times of the elderly group.

3.3.2 Experimental instruments

Besides the newly-designed staplers, the experimental instruments also include another two types of similar staplers on the market, which are taken for comparison in this study. In addition, in order to learn whether grip strength has some influence, grip meters are used to measure the subjects' grip values prior to the experiment; meanwhile, slide calipers are used to measure their hand sizes. NO.10 staple produced by MAX is adopted for all staplers so as to prevent inconsistent results due to different quality of the staplers.

Table 12 Experimental instruments

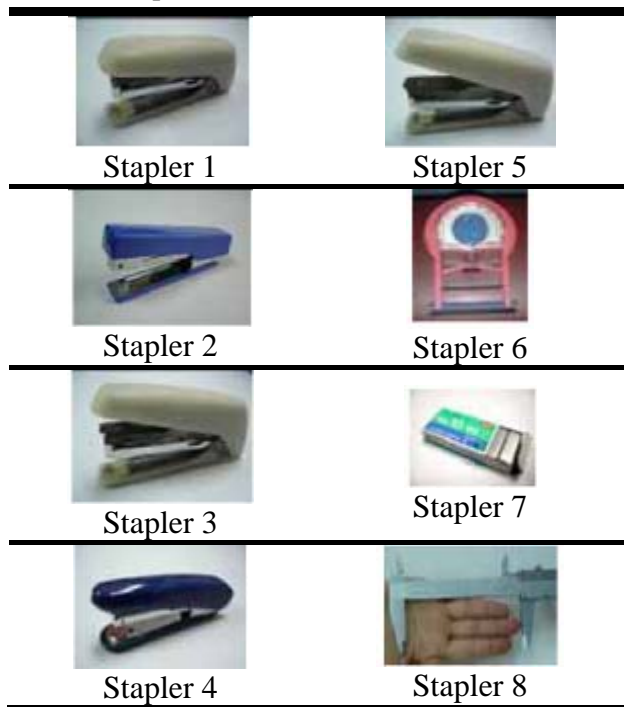

The binding force of these five staplers are shown as below.

Table 13. Binding force for 5&10 pieces of paper (kg)

	5 pieces	10 pieces
Stapler 1	5.9	5.98
Stapler 2	7.78	7.78
Stapler 3	6.3	6.5
Stapler 4	6.92	7.32
Stapler 5	7.4	6.82

4. EXPERIMENTAL RESULTS

This chapter conducts statistic analysis and discussion according to the data of the experimental results. It combines the operating efficiency of the elderly group and the young group with the statistic analysis method to make exploration.

4.1 Analysis of operating efficiency

Through the t-test analysis of the independent sample, we can see that the analysis results show a significant difference between elderly group and the young group in binding 5 pieces of paper($t=8.78$, $p<0.01$), and 10 pieces of paper($t=6.93$, $p<0.01$).

Therefore, the analysis below is performed

respectively for the elderly group and the young group.

Table 14 Single-factor multivariable analysis for the efficiency of the young group and stapler categories when binding 5 pieces of paper

Variation source	Sum of squares	Degree of freedom	Average sum of squares
Subjects	3720.06	1	3720.06
Stapler types	181.840	4	45.460
Subjects* Stapler types	59.440	4	14.860
Inaccuracy	6911.333	140	49.367
Variation source	F-test	Significance	Post comparison
Subjects	75.356	0.000**	Aged>Young
Stapler types	0.921	0.454	
Subjects* Stapler types	0.301	0.301	
Inaccuracy			

(*: $p<0.05$, **: $p<0.01$ ***: $p<0.001$ -:insignificant)

Table 15 Single-factor multivariable analysis for the efficiency of the young group and stapler categories when binding 10 pieces of paper

Variation source	Sum of squares	Degree of freedom	Average sum of squares
Subjects	2205.167	1	2204.167
Stapler types	166.067	4	41.517
Subjects* Stapler types	87.667	4	21.917
Inaccuracy	6556.993	140	46.835
Variation source	F-test	Significance	Post comparison
Subjects	47.062	0.000**	Aged>Young
Stapler types	0.886	0.474	
Subjects*	0.467	0.759	

Stapler types
Inaccuracy

(*:p<0.05, **:p<0.01 ***:p<0.001 -:insignificant)

As shown in table 14 and 15, the efficiency in binding 5 and 10 pieces of paper doesn't show any significant difference between different staplers. However, the efficiency of different test groups shows great difference. In other words, the efficiency of binding 5 or 10 pieces of paper show significant difference between the elderly group and the young group. Therefore, this study makes discussion onto different groups.

As shown in table 18, when using stapler 1, 3, 4 and 5, the elderly spend much more time in binding 10 pieces of paper than that in binding 5 pieces. Thus, the binding efficiency of the new stapler isn't influenced by the number of the binding paper. For stapler 2, the efficiency is slightly increased.

In terms of average seconds, stapler 1 takes the most time in binding 5 pieces of paper, which might be caused by the longer action distance of its structure. However, staplers 2 shows insignificant difference in binding 5 pieces and 10 pieces of paper. Therefore, stapler 2 has no significant difference in using efficiency.

Table 16 Statistical table for average binding time of the elderly group

Group	Elderly group	
	Time needed to bind 5 pieces of paper (Sec)	Time needed to bind 10 pieces of paper (Sec)
Stapler type		
Stapler 1	21.20	16.00
Stapler 2	18.07	18.27
Stapler 3	17.53	15.47
Stapler 4	16.73	14.67
Stapler 5	16.6	13.93

In table 17, the young group shows insignificant difference in binding 5 and 10 pieces of paper with

these 5 types of staplers. The possible reason may be related to the grip strength of this group. During the test by the young group, when being asked about the feeling, they represent no different feeling between binding 5 and 10 pieces of paper. However, stapler 1 takes more time to accomplish the task. The preliminary analysis is the binding efficiency is affected by the longer action distance in its structure, and the same is true in tests conducted by the elderly.

Table 17 Statistical table for average binding time of the young group

Group	Young group	
	Time needed to binding 5 pieces of paper(Sec)	Time needed to binding 10 pieces of paper(Sec)
Stapler type		
Stapler 1	9.00	9.93
Stapler 2	7.93	8.00
Stapler 3	8.20	7.80
Stapler 4	7.00	6.53
Stapler 5	8.20	7.73

4.2 Correlations between the Binding Efficiency and the Grip Strength of the Elderly Group

In regression analysis (Table 20), for the elderly, the efficiency of binding 10 pieces of paper is significantly related to (p<0.001) the grip value. Its R-test value is outstanding (R=0.617), indicating a significantly liner correlation. Therefore, for the elderly, the time needed for binding is clearly shortened with the increase of grip value, which displays a liner status. See Figure 3.

Table 18 Correlation between binding efficiency and grip value

	Binding efficiency
R squares	0.617
Degree of freedom	13
F-test	20.91
Significance	0.001

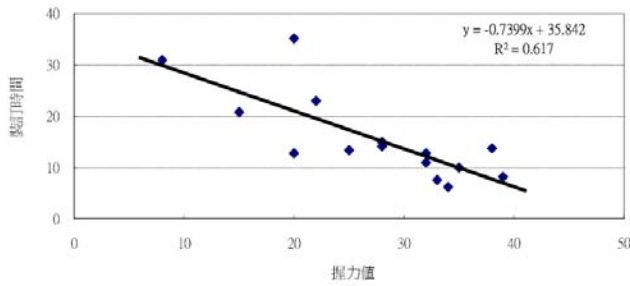

Figure 3

4.3 Correlations between the Binding Efficiency and the Grip Strength of the Young Group

Table 19 Correlation between binding efficiency and grip value

	Binding efficiency
R squares	0.034
Degree of freedom	13
F-test	0.462
Significance	0.509

In table 19, the regression analysis for young group, the efficiency of binding 10 pieces of paper isn't significantly related to the grip strength. Its R-test value isn't outstanding ($R=0.034$). It shows no linear relations.

4.4 Summary

The above statistical analysis results show that:

1. The average time spent by the elderly group in binding is apparently more than that by the young group. Moreover, there are significance and linear relations between binding efficiency and grip value, indicating that grip value directly influence the working efficiency of the elderly group. However, as the ages increasing, besides their physiological functions become to deteriorative, their grip value will decrease as well.
2. Among all samples, the average binding time of stapler 5 is the shortest in terms of the elderly group, while it is stapler 4 for the young group. The main reason is that when binding 10 pieces of paper, the elderly group applies more strength in binding, allowing them in a higher status of their loading. It can be also found out in the regression analysis of

the binding efficiency that higher the value of grip strength is, less time they will spend in the binding. When the elderly group operates stapler 5, the sample stapler integrates the labor-saving structure with the shortest action distance. Therefore, the aged subjects spend least time in binding with stapler 5. For the young subjects, on the other hand, when binding 10 pieces of paper, they just need a lighter load to operate it. Furthermore, staple 4 is of the simplest structure, so its operational time decreases correspondingly. In addition, its operational semantics is easy to understand. Therefore, for the young subjects, as the familiarity increases, the operating efficiency of product is improved as well.

5. CONCLUSIONS AND SUGGESTIONS

5.1 Conclusions

In an aging social structure, the physiological functions of the elderly deteriorate with their increasing age. This study focuses on increasing the working efficiency, by means of improving hand tools, of the elderly group when they deal with low-load and high-frequency office works. Taking this as the start point, this paper discusses the using differences of staplers for different age groups. Conclusions are summarized as follows:

- 1) For labor saving and force application, the stapler with operational height of 42.8mm needs a binding force of 5.98kg. It is the most labor-saving one.
- 2) For binding efficiency, in terms of the three new staplers used by the elderly group in this study, the labor-saving structural design can increase the operability for the elderly group. The most efficient stapler is in the operational height of 55mm followed by 50mm and next 42.8mm.

Through above summary, we can know that the design of stapler not only needs to consider the labor-saving structure, but also a simplified operation. The experimental results reveal that it can increase the whole using efficiency of the elderly group through taking an operational height of 50mm,

reducing the force application to the operation together with shortening the action distance. From this study, we can see that it's not so feasible to increase the complication in operation for adding labor-saving devices to the stapler structure. Excessive improvement may achieve a labor-saving effect, but the whole using efficiency may not be so optimized. On the contrary, it may cause unfamiliarness of users towards the products, resulting in the unwillingness to use.

5.2 Suggestions

This study mainly integrates the new samples with labor-saving structures, analyzing and understanding the using differences between the three newly-designed stapler samples and the products already on the market through the binding efficiency and relevant statistics. For follow-up studies, there are some suggestions to put forward:

- 1) Whether different shapes may apparently influence the elderly's binding efficiency.
- 2) Apply diverse shell materials to explore the influence on the elderly's force application and gripping softness.

REFERENCES

Arthur D. Fisk and Wendy A. Rogers, 2002, Psychology and Aging: Enhancing the lives of an Aging Population, Current directions in psychological science, Vol. 11, No. 3, pp.107-110.

Arthur D. Fisk and Wendy A. Rogers, 2004, Maximizing the usefulness and usability of health care technologies, Designing for older adults, Chapter 9, p 125.

Baltes, P. B., Baltes, M. M., 1990, Selective optimization with compensation, Successful Aging: perspectives from the behavioral sciences, Cambridge University Press, New York, pp.1-34.

Fisk, A. D., Rogers, W. A. (Eds.), 1997, Handbook

of human factors and

the older adult, Academic, San Diego.

Guo Chen Jia, 2001, Study on the Life Products Design of Aging Society, master paper from Graduate School of Industrial Design in National Yunlin University of Science and Technology, Yunlin.

Li Zhi Hui, 2000, Design and Evaluation of Hand Tools—Case Study on Iron Wire Tying Operations, master paper from Graduate School of Industrial Ergonomics and Management in Chung Hua UNIVERSITY, HsinChu.

Lian Jun Ming, 2004, Discussion of the Importance of Recreational Products Designed for the Elderly, proceeding of Challenge of Aging Society towards Industrial Design, International Academic Conference, Tokai University, Taichung, P51.

Zhang Ying Ci, 2005,

<http://www.biopharm.org.tw/media/mdnews/61/6104.html> ← Report of production & technology and medical care facilities, authorized by magazine, 2009/04/20.

Zhan Huo Sheng, Wang Yi Ren, Xiao Hui Ru, June 7, 2002, Safety Policy for the Economy of the Elderly, NPF Research Report, <http://www.npf.org.tw/PUBLICATION/SS/091/SS-R-091-019.htm>, 2009/05/18.

Zhan Huo Sheng (edit), 2000, Make an Appointment of the Ease and Energetic 21st, century, Health, Welfare and Environment Foundation, 1999, proceeding of International Conference of Asian-Pacific Elderly Care, Taipei, P122.