

# QUANTIFICATION OF CHANGES IN SURFACE CONDITIONS OF AIRPORT PAVEMENTS IN JAPAN

Yoshitaka HACHIYA, Takashi WATANABE and Kentaro KITAOCHI  
Service Center of Port Engineering (SCOPE), JAPAN

**ABSTRACT:** An airport pavement management system (APMS) has been under development in Japan. In particular, a surface condition evaluation subsystem based on the method of a Pavement Rehabilitation Index (PRI) has been in use for two decades or more. This PRI method was completed in the early 1980s as a means of evaluating the surface condition of airport pavements by calculation based on objective measurements of surface conditions, as derived from the subjective opinions of pavement engineers. By comparing the calculated PRI value against appropriate criteria, the need for pavement rehabilitation work can be judged for runway, taxiway, and apron pavements. Japan's APMS is described in outline, along with the closely related rehabilitation subsystem. The evaluation of surface conditions using the subsystem is described in detail and use of the results to judge the need for rehabilitation work is explained. In the analysis, the present conditions of airport pavements are summarized, and compared with the results of surveys conducted about 20 years ago. Further, the annual change in pavement condition of Osaka Itami Airport is analyzed.

**KEYWORDS:** airport pavement, surface condition, rehabilitation need

## 1. INTRODUCTION

Airport Pavements require continuous maintenance and rehabilitation works to prevent deterioration caused by repetitive aircraft loading and the action of nature. Recent introduction of larger aircraft and increased aircraft operations have accelerated the process of deterioration. However, with the limited fund for airport pavement work, there is a need to use the available funds as effectively as possible. To accomplish this, a systematic procedure for scheduling maintenance and rehabilitation works to optimize benefits to aircraft pilots, passengers, etc. and minimize costs to the agency responsible for pavement management is recognized as a useful measure. Known as a pavement management system for airports (APMS), such a system would allow administrators and engineers to allocate funds, personnel, resources, etc.

most effectively (Hall, J. W., et al.).

A full APMS is a complicated undertaking and so far a full-fledged system has yet to be developed in Japan (Sato, K. and Hachiya, Y.). However, some subsystems of a complete APMS, including the design, evaluation and rehabilitation subsystems, have come into practical use (Hachiya, Y., et al. (2005), Tsubokawa, Y., et al., Endo, K., et al.). Of these, the evaluation subsystem, and in particular a surface condition survey method, has been in use for two decades or more. At this point in time, it has become necessary to reevaluate the system.

The conventional method of surface condition evaluation is based on empirical and subjective judgments made by airport administrators. As a systematic alternative, a method based on a Pavement Rehabilitation Index (PRI) was developed

to provide an objective evaluation of pavement surface condition, with separate criteria determined for judging the need for rehabilitation work on runway, taxiway, and apron pavements. This method has now been employed for periodic surveys of pavement condition over a period of about 25 years, as already noted. With surveys every three years, a large volume of data on pavement surfaces at various airports has now been collected. By looking at this data, it should be possible to summarize the present condition of airport pavements, evaluate changes in the pavements over time and review the current pavement management system.

This paper focuses on the pavement evaluation subsystem of Japan's APMS. First, an outline of the subsystem is given, introducing also the rehabilitation subsystem, which is a closely related part of the APMS. Then, details are given of the method used to evaluate surface condition using the PRI, which forms the basis for judging the necessity of rehabilitation work. Next, experience in applying the evaluation method to airport asphalt pavements, which are selected for analysis here since their condition change more significantly over time, are described. The analysis includes a summary of the present condition of airport pavements in Japan and the findings are compared with the results of a survey conducted about 20 years ago. Further, the annual change in pavement condition at Osaka Itami Airport is analyzed. Finally, the validity of the PRI method is evaluated.

## 2. EVALUATION AND REHABILITATION SUBSYSTEMS OF APMS IN JAPAN

Once an airport pavement has been opened to traffic, proper maintenance and rehabilitation works are essential to maintaining functionality at a satisfactory level and also to maximizing its service life. Maintenance and rehabilitation strategies were conventionally based on empirical and subjective judgments by the airport engineers. The development

of a systematic method of implementing maintenance and rehabilitation works has been eagerly awaited, as it will enable airport administrators to make the best possible use of available funds.

Through various studies of pavements for airports, including investigations of surface condition evaluation, structural evaluation, prediction of distress and performance, and maintenance and rehabilitation strategies, the airport pavement management system for design, evaluation and rehabilitation has been developed and used for two decades or more.

**Figure 1** shows a flow chart of the evaluation and rehabilitation subsystems, in which fundamental evaluation, and maintenance and rehabilitation process consists of the following steps.

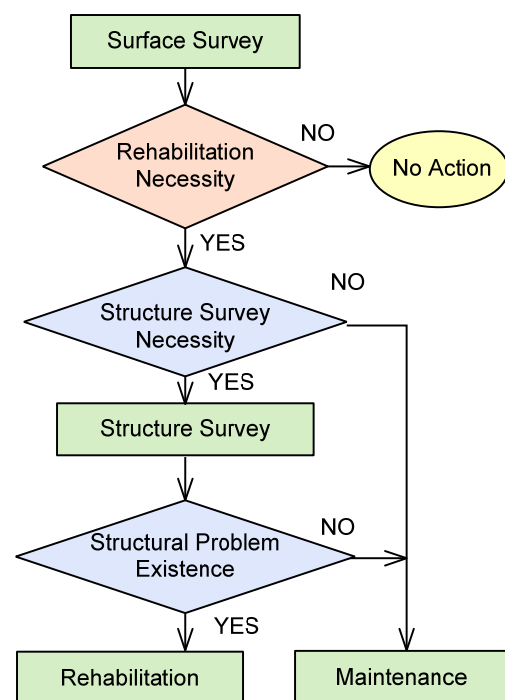

**Figure 1** Flow chart of evaluation and rehabilitation subsystems for airport pavement management

### 1) Surface condition evaluation

The condition of the airport pavement surface is surveyed every three years. When the physical condition of the surface is judged to have seriously deteriorated, certain rehabilitation work may become necessary. In order to determine a suitable time for carrying out this rehabilitation work, an objective method using the already-mentioned PRI has to be applied.

### 2) Structural condition evaluation

If the above-mentioned PRI method indicates that certain rehabilitation work is necessary, the structural condition of the pavement has to be checked. Non-destructive testing procedures using a Falling Weight Deflectometer (FWD) are adopted for airport pavements.

### 3) Rehabilitation method selection

If the structural condition of a pavement is found to be unsound, rehabilitation work is necessary. However, some maintenance work may be needed even if the pavement is sound structurally.

### 4) Rehabilitation work design

Based on the decision made above, the procedure for the rehabilitation work should be determined. In general, there are two methods of rehabilitation, overlay and reconstruction.

## 3. DEVELOPMENT OF PRI SYSTEM

The equations for evaluating pavement serviceability were developed by comparing the opinions of pavement engineers with objective values representing the condition of the pavement surface. 42 distressed sections (a section being 20 m wide and 30 m long) were selected and the opinions of engineers obtained for each using a questionnaire. The results of the questionnaire were formulated using Quantification Theory. Ultimately, three indices were selected as suitable for evaluating pavement surface condition, in consideration of their

ease of measurement (Fukute, T., et al.). They are as follows:

- 1) Cracking, CR (%): the crack ratio, defined as the cracked area divided by the area of the section and expressed as a percentage
- 2) Rutting, RD (mm): the maximum rut depth in the section
- 3) Roughness, SV (mm): the standard deviation of roughness as measured using a 3 m profilometer

Finally, an equation relating the engineers' opinions to these objective measures was developed. It takes the form of polynomials in which the above three factors are explanatory variables. The explained variable in this equation was named the Pavement Rehabilitation Index (PRI), expressed as follows:

$$PRI = 10 - 0.450CR - 0.0511RD - 0.655SV$$

Clearly, a higher value of PRI equates to a pavement in better condition. The need for rehabilitation work in a section is judged by ranking PRI values into three categories, as follows:

- 1) Rank A: rehabilitation work is unnecessary
- 2) Rank B: rehabilitation work will be necessary in the near future
- 3) Rank C: rehabilitation work is necessary immediately

**Table 1** shows the threshold values between these ranks, which differ by the type of airport facilities. This is because very strict control of the surface is necessary for a runway, while surface condition is not critical for apron pavements, where aircraft are stationary or moving only slowly.

**Table 1** PRI Judgment Criteria

Facility	A	B	C
Runway	more than 8.0	8.0 to 3.8	less than 3.8
Taxiway	more than 6.9	6.9 to 3.0	less than 3.0
Apron	more than 5.9	5.9 to 0.0	-

## 4. SURFACE CONDITION OF AIRPORT ASPHALT PAVEMENTS

### 4.1 PRI

At the Japanese airports managed by the Ministry of Land, Infrastructure, Transport and Tourism, periodic checks of pavement condition are carried out (Imanishi, K., et al., Hachiya, Y., Hachiya, Y., et al. (2007)).

**Figure 2** shows the survey results for the state of the asphalt pavement at 23 of these airports, conducted between 1998 and 2002. The PRI values for runways and taxiways are different, with runways averaging 8.0 and taxiways 7.1. There is a difference of about ten percent on average between runways and taxiways, with taxiways exhibiting the smaller

values of PRI. All types of distress, including cracking, rutting, and roughness, are more severe on taxiways than on runways and this is reflected in the PRI.

### 4.2 Needs for Rehabilitation

**Figure 3** shows the need for rehabilitation work as judged from these PRI values in accordance with the criteria given in **Table 1**. Looking at runways, the proportion of pavements classified as A is about 60% and the remainder is B. On the other hand, about 70% of taxiway pavements are ranked as A, but there are some ranked as C. Although PRI values are smaller for taxiways than for runways, the difference in need for rehabilitation results from the different criteria used for runways and taxiways.

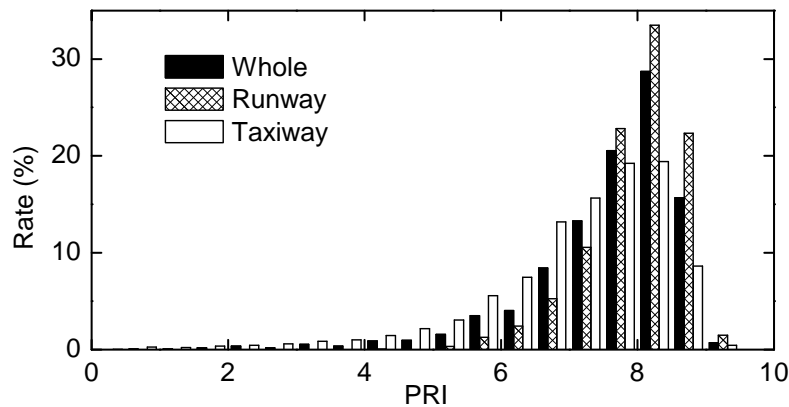

**Figure 2** PRI Distribution

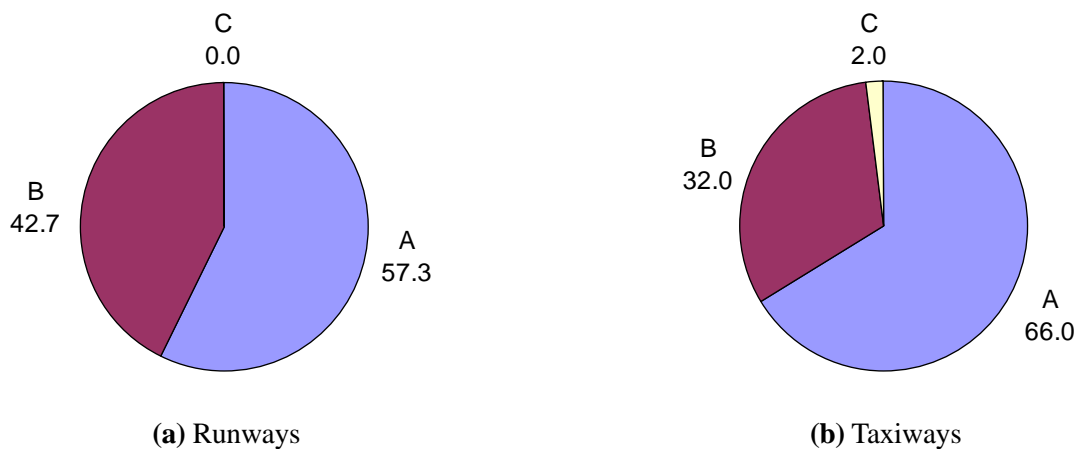

**Figure 3** Need for Rehabilitation Work

### 4.3 Comparison with Past Condition

The survey results as presented above are compared with past results taken between 1985 and 1987 in order to evaluate the validity of the current maintenance and rehabilitation system used for airport pavements (Hachiya, Y., et al. (2008)).

**Figure 4** summarizes the need for rehabilitation work based on PRI. The proportion judged as A is ten points or more lower now than in the past survey, both for runways and taxiways, while there are more B ranks today. However, there is little difference in the proportion judged as C between the current and past surveys.

Clearly, the condition of airport pavement surfaces has worsened in the 20 years since the earlier survey, with the proportion ranked as B increasing over the years. This might suggest that the pavement management system, including the methodology

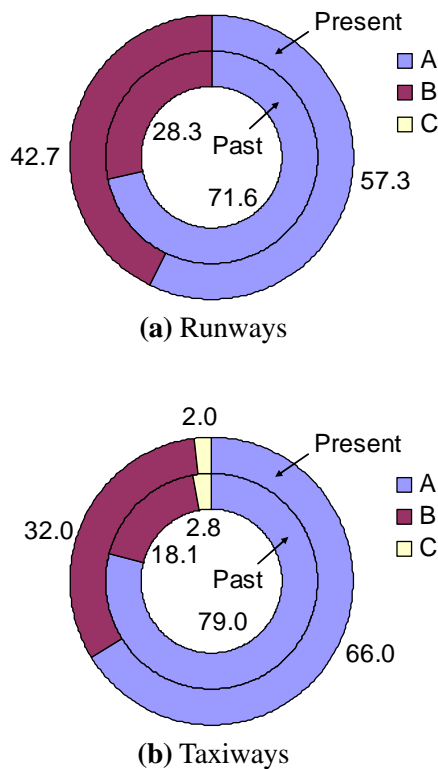

**Figure 4** Comparison of Judged Need for Rehabilitation Present and Past

used to evaluate pavements (the method and the survey interval) is barely adequate to maintain the surface in good condition.

### 5. PAVEMENT SURFACE DISTRESS CONDITION AT OSAKA ITAMI AIRPORT

The surface distress condition of airport pavements was analyzed for Osaka Itami International Airport, one of the large - sized international airports in Japan. Osaka Itami Airport was selected because its plan has not largely changed, various kinds of pavement structures have been constructed, and large-sized aircraft have been introduced. As PRI has been measured at Osaka Itami Airport for about 20 years, both the annual changes in PRI and the recovery of PRI due to rehabilitation works could be calculated with ease.

The surface conditions of runways, taxiways and aprons were evaluated in 163, 273, 101 units, respectively. When the annual changes in PRI and the recovery of PRI due to rehabilitation works are analyzed in each unit, the results vary largely. Thus, the units are summed into several groups as shown in **Figure 5**. The runways A and B were separated into three blocks (two end parts and one intermediate part) in each, and the aprons were divided into nine blocks in consideration of the aircraft running lines. The taxiways were divided into perpendicular taxiways, high-speed exit taxiways and parallel taxiways.

When calculating the annual change in PRI, only the data measured in three or more times between the continuous rehabilitation works are used. For asphalt pavements, the average annual changes in PRI for runways, taxiways are 0.1 - 0.2, 0.1 - 1.2, respectively. The recovered amount of PRI by applying the rehabilitation works scarcely varies in rehabilitation works conducted at Osaka Itami Airport.

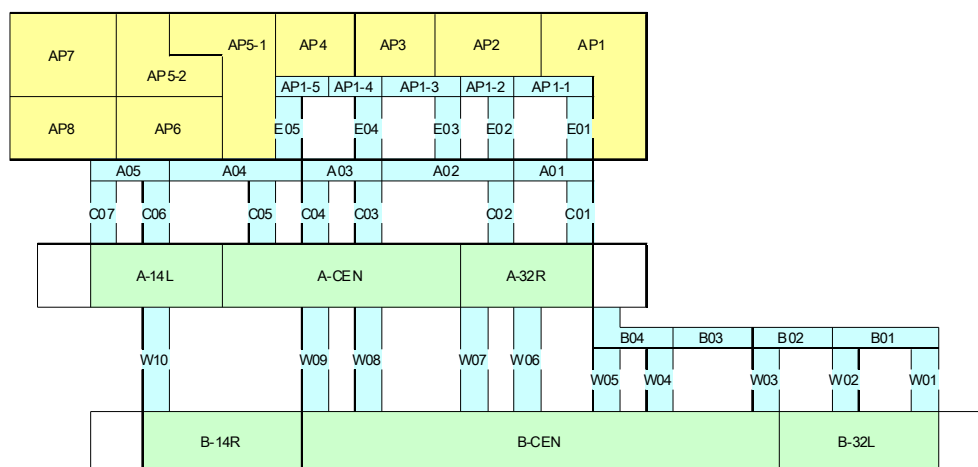

**Figure 5** Groups for PRI calculation at Osaka Itami Airport

## 6. CONCLUSIONS

As a step toward an APMS, subsystem for evaluating the surface condition of airport pavements has been in use in Japan for over 25 years. Using the data collected over this period, the validity of the system has been verified. In this study, the following findings on the surface condition of airport asphalt pavements in Japan have been reached:

- 1) The condition of runway surfaces is better than that of taxiways when quantified by crack ratio, rut depth and roughness. This results in runways having a higher PRI value.
- 2) The need for pavement rehabilitation work is judged at a lower value of PRI for taxiways than for runways, because taxiways play a less crucial role. However, the proportion judged as not needing rehabilitation is about 60% for both types of pavement, which means that airport pavements are, as a whole, maintained well.
- 3) A smaller proportion of pavements are judged as not needing rehabilitation work in the latest survey as compared with a survey carried out 20 years ago.
- 4) The annual rates of change in PRI and the

recovery of PRI due to the rehabilitation works were quantified at Osaka Itami Airport.

## ACKNOWLEDGEMENT

The author acknowledges the Ministry of Land, Infrastructure, Transport and Tourism for its support to accomplish this study.

## REFERENCES

- Endo, K., Himeno, K., Kawamura, A., Hachiya, Y., Matsui, K., 2002. Longitudinal surface profiles of an airport runway and aircraft motion, The 2002 Federal Aviation Administration Technology Transfer Conference, P-27.
- Fukute, T., Sato, K., Hachiya, Y., Yamazaki, H., 1982. Evaluation of serviceability of airport pavements, *Technical Note of Port and Harbor Research Institute*, No.414, 20p. (in Japanese).
- Hachiya, Y., 1988. Actual surface condition of airport pavements, *Technical Note of Port and Harbor Research Institute*, No.634, 40p. (in Japanese).
- Hachiya, Y., Tsubokawa, Y., Umeno, S., 2005. Some

- issues concerning the skid resistance of airport runways, 3rd China/Japan Workshop on Pavement Technologies, pp.270-279.
- Hachiya, Y., Hayano, K., Takeuchi, Y., 2007. Twenty-five years of experience in evaluating the surface condition of asphalt pavements at Japanese airports, Special ICPT Symposium 2007.
- Hachiya, Y., Maekawa, R., Su, K., 2008. Verification of surface condition evaluation subsystem for airport asphalt pavement management in Japan, Transportation Research Board, 87th Annual Meeting.
- Hall, J. W., Grau, R. W., Grogan, W. P., Hachiya, Y., 1992. Performance indications from army airfield pavement management program, *Pavement Management Implementation*, ASTM, STP 1121, pp.297-317.
- Imanishi, K., Hachiya, Y., Tsubokawa, Y., Takeuchi, Y., 2005. Study on annual changes in surface condition of airport pavements, 60th Annual Meeting of Japan Society of Civil Engineers, Section V, pp.287-288 (in Japanese).
- Sato, K., Hachiya, Y., 1987. Development of new evaluation methods and new design methods of rehabilitation works for airport pavements, *Report of Port and Harbor Research Institute*, Vol. 26, No. 5, pp.253-285.
- Tsubokawa, Y., Hachiya, Y., Dong, Q., Himeno, K., Kawamura, A., Mizukami, J., 2005. Study on roughness evaluation of airport pavements based on aircraft response, 3rd China/Japan Workshop on Pavement Technologies, pp.230-238.